

4

3

2

1

REVISIONS

ZONE	REV.	DESCRIPTION	DATE	APPROVED
B3	1 $\triangle A$	CHANGED DIAMETER TOLERANCE TO (+0" -0.015")	6/11/2020	C.Pearson
A3	1 $\triangle B$	CHANGED CUP HEIGHT TO (+0.005 - 0.01")	6/11/2020	C.Pearson
A3	1 $\triangle C$	ADDED POST HEIGHT TOLERANCE ($\pm 0.05"$)	6/11/2020	C.Pearson

8-32 FEMALE THREAD

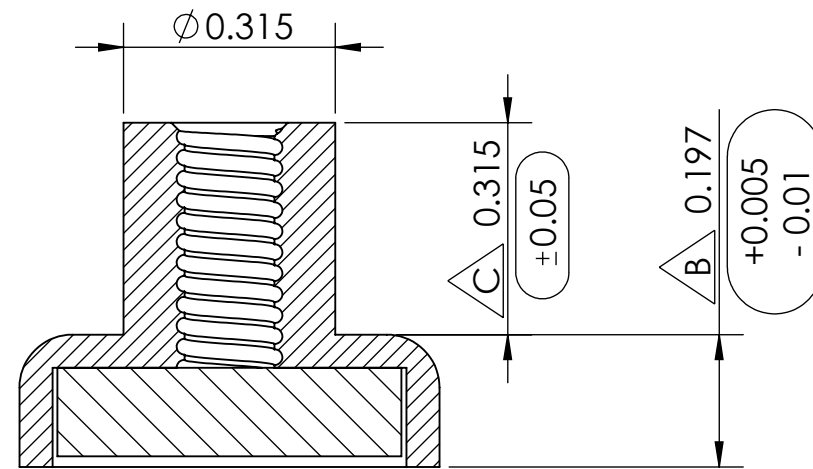
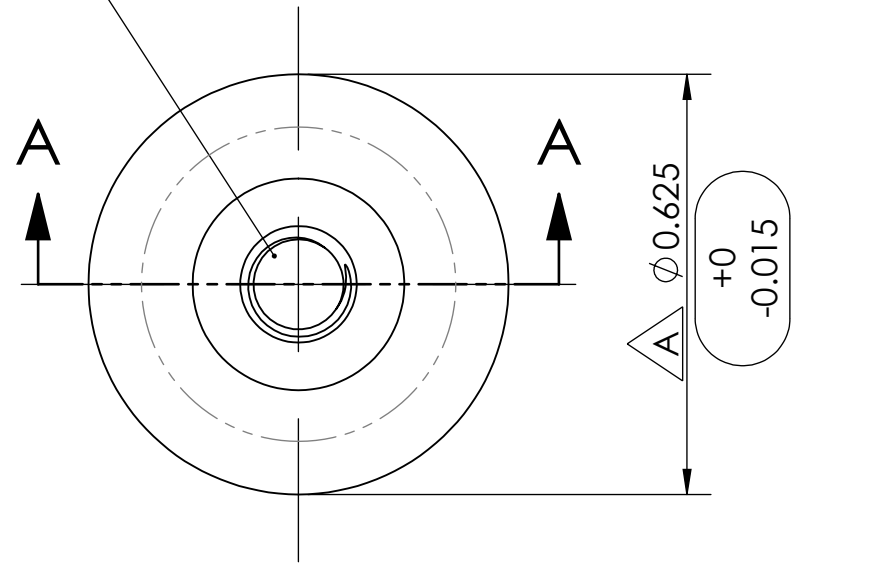

SECTION A-A

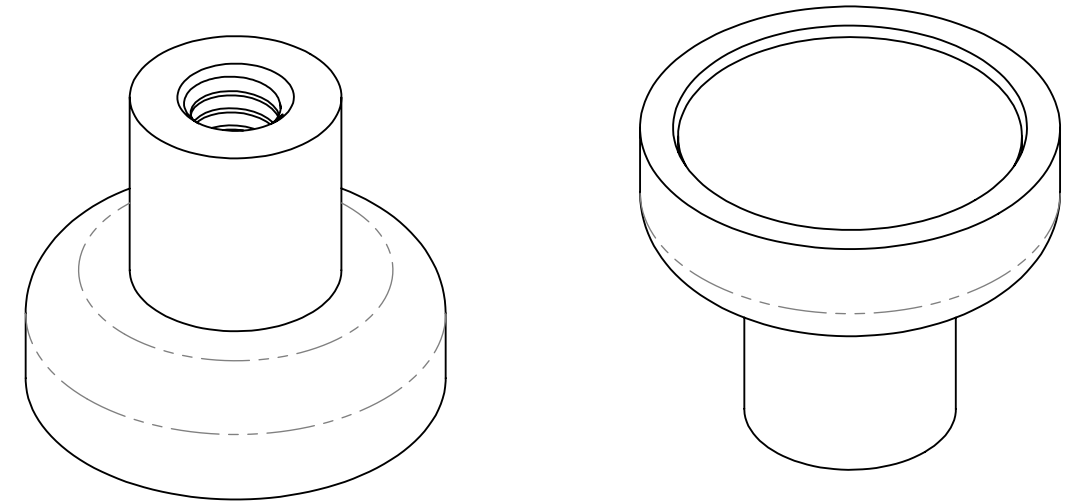

CONDITIONS

- PART IS TO BE FREE OF SCRATCHES, DENTS, AND DEFECTS CAUSED DURING PRODUCTION.
- PART IS TO BE FREE OF GREASE, AND DISCOLORATION ON ALL SURFACES.

MAGNETIC PROPERTIES

- MATERIAL: LICENSED NdFeB
- GRADE: N40
- COATING: Ni-Cu-Ni (NICKEL-COPPER-NICKEL)
- MAGNETIZED: YES
- RESIDUAL INDUCTION (Br): 12.5-12.8 KOe
- COERCIVE FORCE (Hcb): ≥ 10.9 KOe
- INTRINSIC COERCIVE FORCE (Hci): ≥ 12.0 KOe
- MAXIMUM ENERGY PRODUCT (BHmax): 38-41 MGOe
- MAXIMUM OPERATIONAL TEMPERATURE: 80C / 176F

PROPRIETARY AND CONFIDENTIAL

THE INFORMATION CONTAINED IN THIS DRAWING IS THE SOLE PROPERTY OF AMAZING MAGNETS LLC. ANY REPRODUCTION IN PART OR AS A WHOLE WITHOUT THE WRITTEN PERMISSION OF AMAZING MAGNETS LLC IS PROHIBITED.

CAGE CODE
4R1R7

UNLESS OTHERWISE SPECIFIED

DIMENSIONS ARE IN INCHES
TOLERANCES:
FRACTIONAL $\pm 1/64$
ANGULAR: MACH $\pm 1^\circ$
TWO PLACE DECIMAL $\pm .005$
THREE PLACE DECIMAL $\pm .004$

DO NOT SCALE DRAWING

NAME	DATE
DRAWN: L.Bilsoly	6/11/2020
CHECKED: S.Witte	6/11/2020

COMMENTS:



TITLE: CUPF625

SIZE	DWG. NO.	REV
B	CUPF625-SPECS	1

4

3

2

1